

SG-LP SERIES

Thanks to its completely new housing and fixing system **SG-LP laser pointer** can be installed in all safety light curtains profiles of **SE, SG2, SG4-B and SG Body series**. Exactly as the previous model SE-LP, the **installation is performed through one of two lateral grooves**; but, thanks to a specially designed CAMME fixing equipment the laser pointer can be inserted into the groove either from the top or from the side, depending on which kind of fixing brackets have been used to mount the safety light curtain (standard "L" or TOP-BOTTOM Rotating ones). One top and one lateral fixing brackets, together with two tightening knobs allow to adjust SG-LP laser pointer's position in both transversal and longitudinal directions and to have it constantly centred respect light curtain's optical axis, independently from housing width.



HIGHLIGHTS

- To be used to help the mechanical alignment of TX and RX unit of safety light curtain;
- Suitable for all SE, SG2, SG4-B and SG Body profiles;
- Installation performed through one of two lateral grooves of the safety light curtain housing;
- Insertion into the groove either from the top or from the side, depending on which kind of fixing brackets have been used;
- Double adjustment, transversal and longitudinal directions, thanks to one top and one lateral fixing brackets, together with two tightening knobs.

APPLICATIONS

SG-LP laser pointer is advised to be used to ease TX and RX mechanical alignment process in the following installation conditions:

- Multi-beam body/access protection safety light curtain;
- Multi-beam body/access protection safety light curtain installed with deviating mirrors to perform perimetric protections;
- Finger or hand protection safety light curtains installed with deviating mirrors to protect different sides of a machine.

SAFETY PRECAUTIONS

The SG-LP laser pointer uses a red laser light beam that can be potentially dangerous to the human eye.



LASER RADIATION	P = ≤ 1 mW
DO NOT STARE INTO BEAM	λ = 640...660 nm
CLASS 2 LASER PRODUCT	
EN 60825-1 (1994) + A1 (2002) + A2 (2001)	

DIMENSIONS

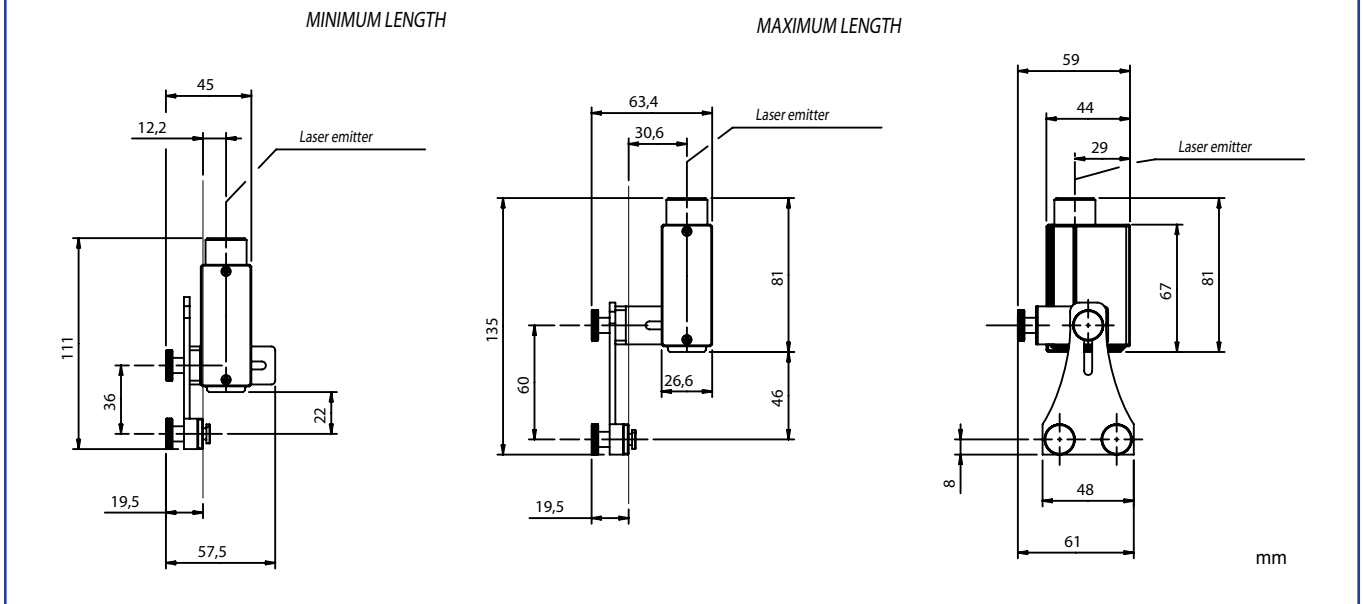

AVAILABLE MODELS

MODEL	DESCRIPTION	ORDER N°
SG-LP	SG-LP LASER POINTER	95ASE5590

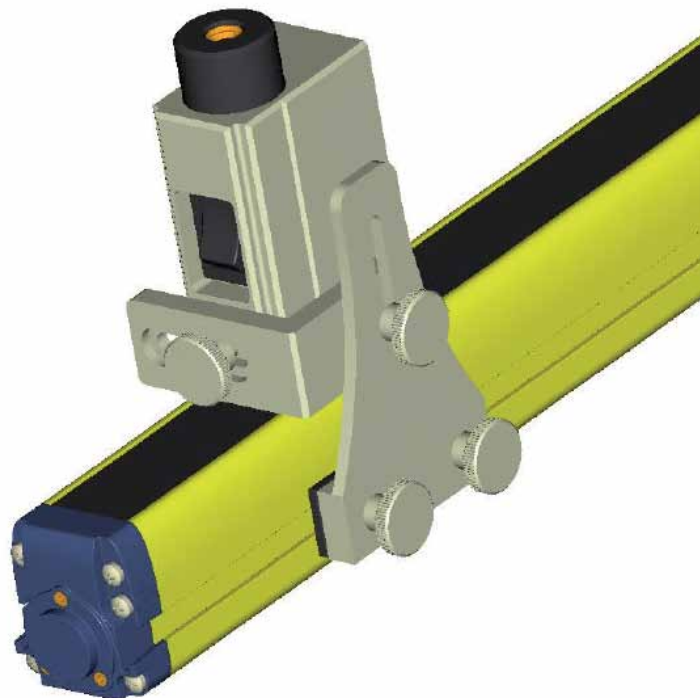

The company endeavours to continuously improve and renew its products; for this reason the technical data and contents of this catalogue may undergo variations without prior notice. For correct installation and use, the company can guarantee only the data indicated in the instruction manual supplied with the products.